



**Gayatri Vidya Parishad College of Engineering for Women**

Madhurawada, Visakhapatnam, 530048  
(Affiliated to JNTUK, Approved by AICTE, New Delhi)

**DEPARTMENT OF ELECTRICAL AND ELECTRONICS ENGINEERING**

# *Vidyut- 2k18*

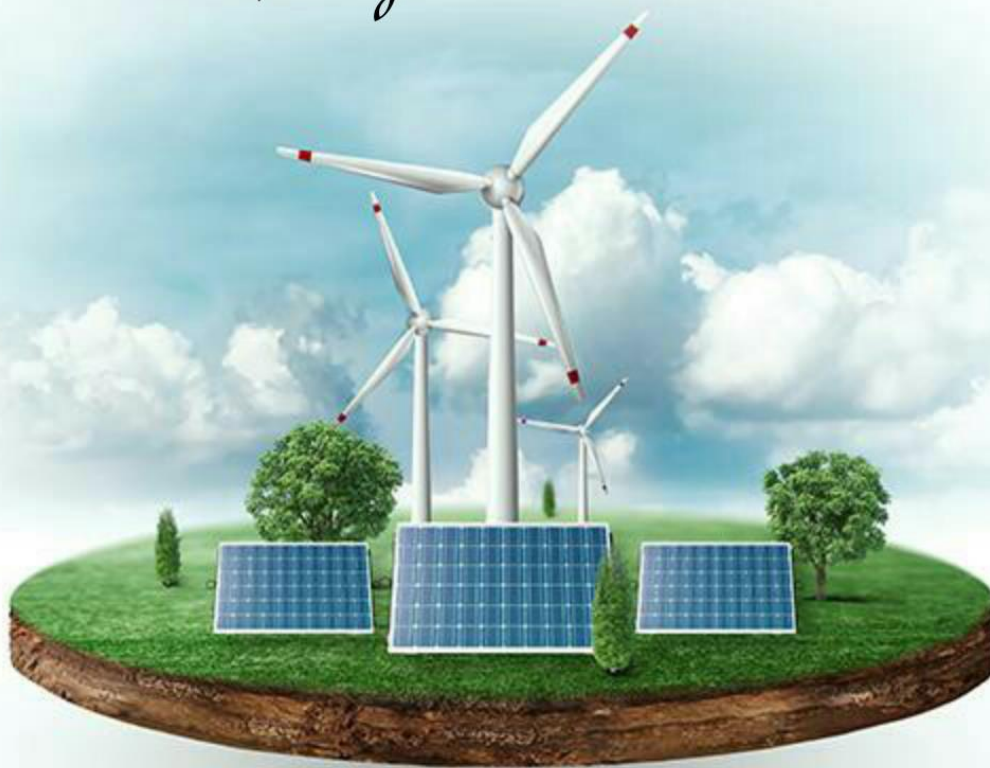

## **Issue 2**

*The Nation That Leads in Renewable Energy  
will be The Nation That Leads The World*

## INDEX

➤ Director's Message.....	3
➤ Principal's Message.....	4
➤ HOD'S Message.....	5
➤ Editorial.....	6
➤ Know a scientist.....	8
➤ Faculty Article.....	9
➤ Student Article.....	14
➤ Department Activities.....	24
➤ Student Activities.....	27
➤ Student Corner.....	31
➤ Contributions and Achievements.....	36
➤ Editorial Board Members.....	38

## DIRECTOR'S MESSAGE



I am very much delighted and pleased to know that the College is bringing out a Magazine with good and useful information on Engineering and Technology and also the available infrastructure and facilities provided for the benefit of students and Faculty.

The efforts by the faculty and students to bring out this magazine with a beautiful getup needs a good word of appreciation. I wish this would continue in future too which certainly upholds the academic environment and decorum of this campus. Let me thank all the senior teachers and the other faculty who had shared their experiences by their rich and highly informative contributions to the Magazine.

As I embark upon my journey as the Principal for Gayatri Vidya Parishad College of Engineering for Women, I am jubilant to meet through this page which is a driving force for the students and faculty at GVPCEW to be proactive towards learning. As we try to prepare the students always to "Think and Review" so as to discover the cause and effect of every event, would surely reveal the hidden talents of the academic fraternity. It gives me immense pleasure to encapsulate yet another occasion of success. I congratulate everyone who endeavours towards our cherished motto of empowering the students for all round development through technical education. Thorough acquisition of knowledge fringed with skills required and character building is our promise by providing necessary resources and resourceful intelligentsia ensuring expected settlement.

## PRINCIPAL'S MESSAGE



I am very much delighted and pleased to know that the College is bringing out a Magazine with good and useful information on Engineering and Technology and also the available infrastructure and facilities provided for the benefit of students and Faculty.

The efforts by the faculty and students to bring out this magazine with a beautiful getup needs a good word of appreciation. I wish this would continue in future too which certainly upholds the academic environment and decorum of this campus. Let me thank all the senior teachers and the other faculty who had shared their experiences by their rich and highly informative contributions to the Magazine. I am a staunch believer that the actions speak more than the words and that everybody must keep his promises to discharge duties as a responsible person of the society.

My hearty congratulations to all those concerned in planning, organizing and bringing out this colourful product which I believe, keeps this college in the limelight amongst all the institutions in and around Visakhapatnam.

Our progressive management looks forward and wishes that our institute raises to the occasion by standing in the privileged front row. Steps are being taken in this direction and fruits of these efforts will be shared by our students in the near future.

## HOD'S MESSAGE



The G.V.P. College of Engineering for Women is facilitating such a nice platform to the students of all branches to prove themselves and enrich their knowledge. Hope that each participant will enjoy the academic flavours of all programs and gain high confidence levels. I wish the program to be a grand success.

Educational institutions are the "temples of learning".in parlance of great thinkers. It is institutions which create individual values as contributing citizens of India.

Profession of Engineering is old as human life is yet to be synchronized globally thereby giving deserved respectability to the engineer. It is in this direction much work need to be done through continuous productive interactions between institutions, industrial associations and global regulatory bodies.

It is interesting to learn about the institution's services rendered in shaping lives of youngsters who arrive as raw individuals at the portals of this institution. Deep rooted conviction of management combined with dedicated faculty has made us stand out as an institution of reckoning for the past 10 years. Our best wishes to every member of the team for making expressions become the much awaited magazine of Indian fraternity.

We are happy to bring out the this issue of " VIDYUT" for the year 2018. The magazine.. In this issue the faculty article is on 'Experimental implementation of Flower Pollination Algorithm (FPA) for speed controller of a BLDC motor ' by Dr. P.Devendra, Associate Professor, who has neatly explained the concept of FPA and how it is applied for speed control of BLDC Motor to the readers. There are two student articles one on "Smart Grid Technologies and its applications" and the other on electric vehicles. The article have introduced the concepts in the beautiful manner. This is followed by the regular sections of Technology Review, Know a Scientist, Short Story and Puzzles, Arts. This issue also contains the contributions and achievements of the students and faculty of the department during the year. We are thankful to the entire department for their continuous support in bringing this issue successful.

## VISION

To develop into a centre of learning that empowers students with contemporary knowledge in Electrical and Electronics Engineering

## MISSION

- . Impart skills both in traditional and modern areas of Electrical & Electronics Engineering
- Provide exposure to latest developments in the field through Seminars, Industrial visits, Workshops and Paper presentations.
- Prepare the young minds to apply professional engineering practices by considering environmental and societal needs.

## PROGRAM EDUCATIONAL OBJECTIVES

**After successful completion of the program, the graduates will be able to:**

- **PEO-1:** Possess a strong educational foundation in mathematics, science, electrical engineering and soft skills in the diversified sectors of the industry.
- **PEO-2:** Exhibit critical thinking, problem-solving skills, and design systems in professional engineering practice.
- **PEO-3:** Establish leading and supportive positions in society by adopting lifelong learning skills with a commitment to their ethical and social responsibilities.

## KNOW A SCIENTIST

Michael Faraday - September 1791 – 25 August 1867, was an English scientist who contributed to the study of electromagnetism and electrochemistry. His main discoveries include the principles underlying electromagnetic induction,, diamagnetism and electrolysis.

Faraday was one of the most influential scientists in history. It was by his research on the magnetic field around a conductor carrying a direct current that Faraday established the basis for the concept of the electromagnetic field in physics. Faraday also established that magnetism could affect rays of light and that there was an underlying relationship between the two phenomena. He similarly discovered the principles of electromagnetic induction and diamagnetism, and the laws of electrolysis. His inventions of electromagnetic rotary devices formed the foundation of electric motor technology, and it was largely due to his efforts that electricity became practical for use in technology.



Faraday was an excellent experimentalist who conveyed his ideas in clear and simple language; his mathematical abilities, however, did not extend as far as trigonometry and were limited to the simplest algebra.

James Clerk Maxwell took the work of Faraday and others and summarized it in a set of equations which is accepted as the basis of all modern theories of electromagnetic phenomena. On Faraday's uses of lines of force, Maxwell wrote that they show Faraday "to have been in reality a mathematician of a very high order – one from whom the mathematicians of the future may derive valuable and fertile methods." The SI unit of capacitance is named in his honour: the farad.

As a chemist, Faraday discovered benzene, investigated the clathrate hydrate of chlorine, invented an early form of the Bunsen burner and the system of oxidation numbers, and popularised terminology such as "anode", "cathode", "electrode" and "ion". Faraday ultimately became the first and foremost Fullerian Professor of Chemistry at the Royal Institution, a lifetime position.

Albert Einstein kept a picture of Faraday on his study wall, alongside pictures of Isaac Newton and James Clerk Maxwell.[4] Physicist Ernest Rutherford stated, "When we consider the magnitude and extent of his discoveries and their influence on the progress of science and of industry, there is no honour too great to pay to the memory of Faraday, one of the greatest scientific discoverers of all time.



# Implementation Of Flower Pollination Algorithm

Dr.P.Devendra  
Associate Professor  
EEE Department

## INTRODUCTION

Flower Pollination algorithm (FPA) in the year 2012, Xin-She Yang proposed this algorithm which emulates the natural behavior of Pollination process involved in the flowering plants. Insects like butterflies, birds, animals bats etc. are the pollinators in the process of pollination. There are two forms of pollination methods viz. biotic and abiotic. Method in which pollinators like insects or birds are involved in pollination is called biotic and in contrary the pollination without any external pollinators is called as abiotic. About 90% of pollination occurs through biotic pollination. Further, pollination process can also be classified as self-pollination or cross-pollination [23]. The cross-pollination is nothing but transfer of the pollen from one flowering plant to flower of a different plant whereas the self-pollination is related to pollination in the same flowering plant from one flower to other flower where it does not require any pollinator. The pollination between flowers at longer distances is called as global pollination. Hence in the algorithm, these pollinators may jump long steps and must follow the L'evy distribution function. Furthermore, flower constancy can be used an incremental step based on the similarity or difference of two flowers. One can read more details of the algorithm in [23–25]. The major characteristics of the flower

pollination algorithm are described from (4)–(7).

Flow chart for implementation of the algorithm is shown in Figure and their settings are: Population, Absorption coefficient, Mutation coefficient, Attraction coefficient, Damping ratio and Iterations.

**Characteristics of flower pollination :** The main purpose of a flower is reproduction via pollination. Flower pollination is correlating with the transfer of pollen, which often associated with pollinators. Pollination appears in two forms: abiotic and biotic.

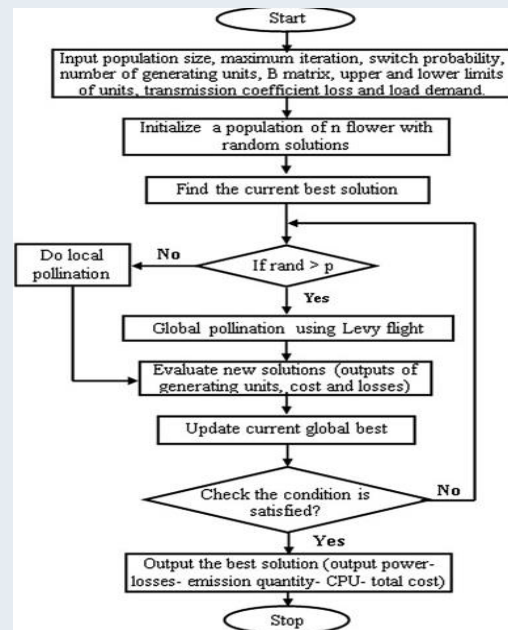

Most of flowering plants depend on the biotic pollination process. In which the pollen is transferred by pollinators. The rest of pollination follows abiotic form that does

not need any pollinators [43]. Wind and diffusion help in pollination process of such flowering plants [44]. Pollination can be achieved by self-pollination or cross-pollination. Self-pollination is the pollination of one flower from pollen of the same flower. Cross-pollination is the pollination from pollen of a flower of different plants. The objective of flower pollination is the survival of the fittest and the optimal reproduction of plants. This can be considered as an optimization process of plant species. All of these factors and processes of flower pollination created optimal reproduction of the flowering plants [44].

#### **Computational Steps for Flower pollination algorithm:**

For FPA, the following four steps are used:

**Step 1:** Global pollination represented in biotic and crosspollination processes, as pollen-carrying pollinators fly following Levy flight [45].

**Step 2:** Local pollination represented in abiotic and selfpollination as the process does not require any pollinators.

**Step 3:** Flower constancy which can be developed by insects, which is on a par with a reproduction probability that is proportional to the similarity of two flowers involved.

**Step 4:** The interaction of local pollination and global pollination is controlled by a switch probability  $p \in [0,1]$ , lightly biased toward local pollination. The above rules have to be converted into proper updating equations.

#### **Implementation of FPA to control BLDC Motor:**

**Introduction:** Electrical motor is an essential element for most of the real-life applications. Widespread use of electric

motor drives of various sizes is operational throughout the world, and they have significant impact on the energy saving when energy efficient electric drives [1] are being developed. In the recent past, the conditions have been changed in adjustable speed drives due to the availability of power semiconductor devices with ratings up to 6000 V and 3000 A without even connecting a series or paralleling the devices [2–4]. The three phase BLDC motors have been rapidly emerging in many industrial, household, commercial and automotive applications over the past several years because of its advantages like control flexibility, high torque capability, noiseless operation, more efficiency, lesser size and volume as compared to the conventional motors. Hence it is reducing fuel emissions and consumption.

There are basically two types of Brushless DC (BLDC) motors, viz. Permanent Magnet Synchronous Motor (PMSM) and BLDC motors depending on their flux distribution. The motor which has a trapezoidal wave shape is called as a BLDC motor, whereas the PMSM has a sinusoidal back-EMF wave shape. The control of BLDC motor can be classified as sensor-based control and sensorless control. In sensor-based control, the stator winding is excited based on rotor position which is measured using hall sensors [5]. PID controllers are commonly used in speed control of BLDC motor. However, the performance of a speed controller mainly depends on tuning of PID gains. Tuning is nothing but finding appropriate proportional, integral, and derivative gains of PID controller to meet the desired performance. Tuning of the PID controller is a complex task which is mainly done by either trial and error or rule based methods. The Ziegler-Nichols tuning method is the most well-known tuning method based on thumb rules. Recently, researchers have

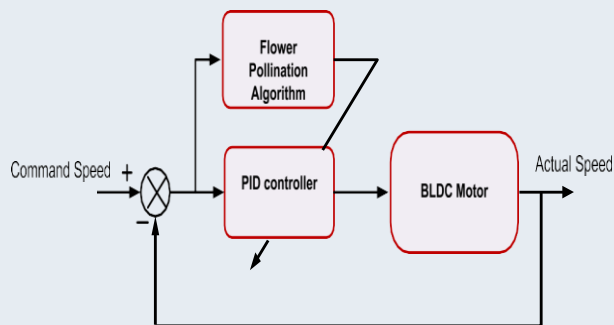

proposed several optimization based approaches for many applications by selecting an integral square error (ISE) as the objective function for PID tuning.

However, all the conventional optimization methods do not solve the complex engineering problems associated with higher nonlinearity. The Flower Pollination algorithm is an efficient nature-inspired metaheuristic algorithm can circumvent the challenges associated with higher nonlinearity of the problem. In the present work, PID gains are tuned for the non-linear BLDC motor using Flower Pollination Algorithm which utilizes the pollination behavior of flowered plants. The efficacy of the work has been validated through real-time implementation with dSPACE DS1103 controller board. In addition one can implement recently proposed methods in [15–17] for sensorless speed control of BLDC motor with the Flower Pollination Algorithm.

### Experimental implementation:

Hardware implementation of the proposed work is shown in Fig.1. In the present work, a BLDC motor with incremental encoder is used to measure angular position and speed of the motor. The dSPACE DS1103 controller board has been facilitated with A/D and D/A converters. The board is equipped with a slave DSP processor, TMS320F240 for enabling advanced I/O functions [26]. The connector panel CLP 1103 of the dSPACE controller board is used to connect the

encoders, hall position sensors and current transducers etc. [24–26]. In the proposed work, incremental encoder with a pulse count of 2000 pulses/revolution is used for measuring speed and position [26,28]. The communication with the computer is performed through an optical fiber cable. The Intelligent Inverter used as Voltage Source Inverter which consists of various subsystems such as Rectifier & Filter, Inverter circuit, Optoisolator, Gate Driver, Current Sensor, Signal conditioner and Protection Circuit. Interfacing of encoder is done by RTI blocks facilitated in the DS1103 controller board. The developed MATLAB/Simulink simulation file with embedded functions and high level inbuilt functions are connected to RTI (Real Time Interface) blocks of dSPACE DS1103. The RTI blocks facilitate the reading of encoder values, Analog inputs and digital inputs to the MATLAB/Simulink environment. The dSPACE DS1103 also consists of real-time software called Control Desk which is used for online variation of parameters and data acquisition [27].

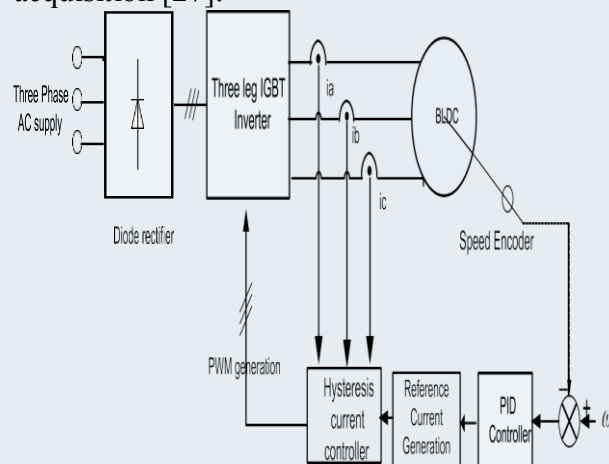

Fig. shows a typical BLDC Motor Drive Scheme

### CONCLUSIONS:

FPA optimization is a promising technique for solving complicated problems in power systems. Applications of the proposed algorithm

to multi-area power system integration with renewable energy sources and systems. Performance of the proposed algorithm has been investigated in hardware implementation with a laboratory setup. The performance of closed loop speed control is tested for different scenarios such as ramp, stepped, sinusoidal, and step speed commands. The effectiveness of the proposed method for closed loop control of the BLDC motor drive is compared with conventional Zeigler-Nichols PID tuning, and also with some well-known nature inspired optimization algorithms such as Firefly and PSO in terms of absolute mean error. It is observed that absolute mean speed error in closed loop speed control with Flower Pollination Algorithm is negligibly small as compared to PSO, firefly and Zeigler-Nichols method. The drive performance is also demonstrated for different types of reference speeds. However, this approach is suitable for testing the performance of the drive in off line with fixed PID gains but has given superior performance characteristics as compared to conventional methods. All the results are experimentally validated for BLDC motor drive using dSPACE DS 1103.

## REFERENCES

1. Singh B. Recent advances in permanent magnet brushless DC motors. *Sadhana* 1997;22(6):837–53.
2. Bose BK. Power electronics and motor drives - technology advances, trends and applications. 2005 IEEE International Conference on Industrial

Technology, no. 2000, 2005.

3. Singh B, Singh S. State of the art on permanent magnet brushless DC motor drives. *J Power Electron* 2009;9:1–17
4. Chaib L, Choucha A, Arif S. Optimal design and tuning of novel fractional order PID power system stabilizer using a new metaheuristic Bat algorithm. *Ain Shams Eng J* 2017;8(2):113–25
5. Saad NH, El-Sattar AA, Mansour AE-AM. A novel control strategy for grid connected hybrid renewable energy systems using improved particle swarm optimization. *Ain Shams Eng J* 2018;9(4):2195–214.
6. El-samahy AA, Shamseldin MA. Brushless DC motor tracking control using self-tuning fuzzy PID control and model reference adaptive control. *Ain Shams Eng J* 2018;9(3):341–52.
7. Ibrahim HEA, Hassan FN, Shomer AO. Optimal PID control of a brushless DC motor using PSO and BF techniques. *Ain Shams Eng J* 2014;5(2):391–8.
8. Valle RL, de Almeida PM, Ferreira AA, Barbosa PG. Unipolar PWM predictive current-mode control of a variable-speed low inductance BLDC motor drive. *IET Electr Power Appl* 2017;11(5):688–96.
9. Pillay P, Krishnan R. Modeling of permanent magnet motor drives. *IEEE Trans Ind Electron* 1988;35(4):537–41.
10. Krishnan Ramu. Permanent magnet

synchronous and brushless DC motor drives. CRC Press; 2009.

Syst Inform Technol 2017:4–16.

11. Abramov IV, Nikitin YR, Abramov AI, Sosnovich EV, Božek P. Control and diagnostic model of brushless Dc motor. J Electric Eng 2014;65(5):277–82.

12. Wang K, Rahman, Ma, Shen JX. Control of high-speed sensorless PM brushless DC motors. IEEE Industry applications society conference record – IAS annual meeting, 2010.

13. Yang X, Karamanoglu M, He X. Multi-objective Flower Algorithm for optimization. Procedia Comput Sci 2013;18:861–8.

14. Yang XS, Karamanoglu M, He X. Flower pollination algorithm: a novel approach for multiobjective optimization. Eng Optim 2014;46(9):1222–37.

15. Łukasik S, Kowalski PA. Study of flower pollination algorithm for continuous optimization. Adv Intell Syst Comput 2015;322:451–9.

16. Potnuru D, et al., Derivative-free square-root cubature Kalman filter for non- linear brushless DC motors; 2016:1–11.

17. Ghaffari A. dSPACE and real-time interface in simulink. 2012;12.

18. Potnuru D, Alice Mary K, Saibabu Ch. Design and implementation methodology for rapid control prototyping of closed loop speed control for BLDC motor. J Electric

# DC-DC CONVERTER FOR ELECTRIC VEHICLES

Juhe Sravani,

3/4 B Tech.

## INTRODUCTION:

An electric vehicle, also called an EV, uses one or more electric motors or traction motors for propulsion. An electric vehicle may be powered through a collector system by electricity from an electric vehicle, also called an EV, uses one or more electric motors off-vehicle sources, or may be self-contained with a battery, solar panels or an electric generator to convert fuel to electricity. EVs include, but are not limited to, road and rail vehicles, surface and underwater vessels, electric aircraft and electric spacecraft.

EVs first came into the mid-19th century, when electricity was among the preferred methods for motor vehicle propulsion, providing a level of comfort and ease of operation that could not be achieved by the gasoline cars of the time. Modern internal combustion engines have been the dominant propulsion method for motor vehicles for almost 100 years, but electric power has remained commonplace in other vehicle types, such as trains and smaller vehicles of all types.

In the 21st century, EVs saw resurgence due to technological developments, and an increased focus on renewable energy. Government incentives to increase adoptions have been introduced in many countries. Electric vehicles are expected to increase from 2% of global share in 2016 to 22% in 2030.

## Advantages of Electric Vehicles

There are a number of great benefits to electric vehicles (EVs) over conventional petrol/diesel cars.

Cheaper to run

- Cheaper to maintain
- Better for the environment
- Health benefits
- Safety improvements

## MODELLING OF BOOST CONVERTER

### Converter Basic Circuit

The simple circuit configuration of the boost converter is as shown in the Fig.2. Boost converters consist of a diode, switch, an inductor and a capacitor and give a stepped-up output. This converter has high efficiency while maintaining its simplicity. The voltage source can come from any DC sources. This includes solar panels and batteries. During Continuous Conduction Mode (CCM) operation, the boost converter operation will be as shown in Fig.3 during the ON state of the switch, S whereby, the inductor current will never be zero and the input voltage will appear across the inductor. And during the OFF state of S, the operation will be as in Fig.4 where the inductor current will flow through the load.

### Modelling

The equations used in modelling the circuit are discussed. The first step of the calculation of the circuit parameters will be to calculate the duty cycle.

The duty cycle of the converter will be:

$$D = 1 - \frac{(V_{OUT} + V_{FWD})}{(V_{IN(min)} + V_{OUT} + V_{FWD})}$$

The efficiency value,  $\eta$ , is usually taken at 80% which is not an unrealistic value for a boost converter. This can be considered as worst case efficiency.

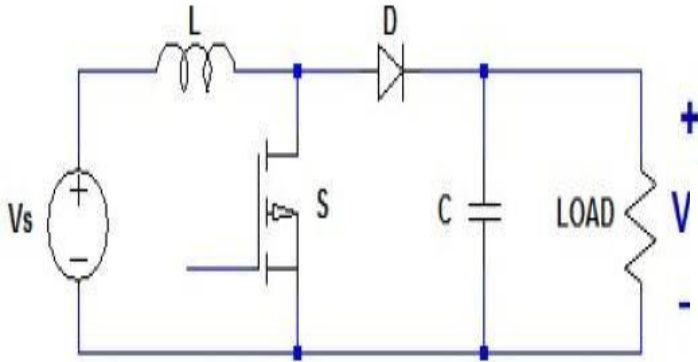

Fig. 2. General configuration of boost converter

$$L = \frac{V_{IN(min)} \times D_{(max)}}{\Delta I_L \times f_{SW(min)}} \quad (4)$$

In Eq. (3), the input current is divided by the worst case efficiency and then multiplied by the determined inductor ripple current. The calculations for the minimum inductor value are as shown above. In (4), the minimum value of input voltage will be multiplied with the maximum duty cycle and the divided by the product of the calculated inductor ripple current in (3) and the minimum switching frequency.

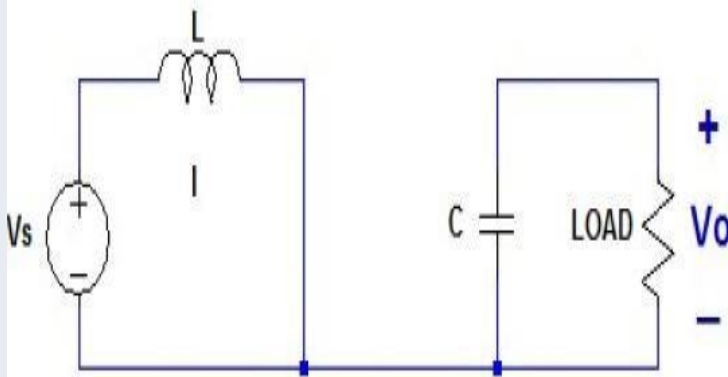

Fig. 3. Operation of boost converter during ON state

$$I_{OUT(max)} = \left( I_{LIM(min)} - \frac{\Delta I_L}{\eta} \right) \times (1 - D) \quad (5)$$

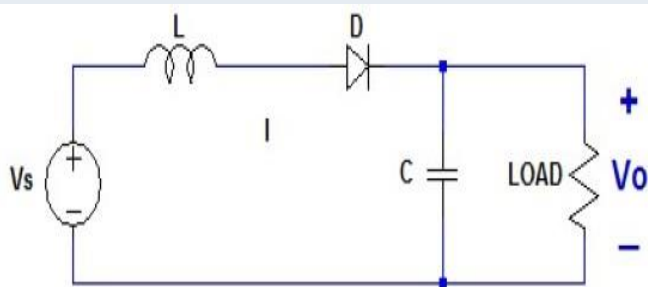

Fig. 4. Operation of boost converter during OFF state

In selecting the passive components, the inductor ripple current needs to be determined first which is usually set between 20-40% of the input current. This can be observed from the equation:

$$\Delta I_L = 30\% \times \frac{I_{IN}}{\eta} = 30\% \times I'_{IN} \quad (3)$$

Where, the in Eq. (1) is the forward voltage drop of the diode while the input voltage value is taken at a minimum value as this will give the value of maximum switching current. represents the desired output voltage from the converter. Eq. (1) can also be written as in the form of Eq. (2) where the relation between input and output

current with duty cycle will be observed:

These calculations are based on the

$$I_{C_{OUT}(RMS)} = I_{OUT} \times \sqrt{\frac{D_{(max)}}{1 - D_{(max)}}} \quad (12)$$

power stage of boost converters which comes with an IC that contains an integrated switch. Thus, it is crucial to know if the selected IC for the converter can deliver the expected maximum value of current. In the equation, (5) represents the minimum value of current limit of the IC while the other values such as duty cycle and inductor ripple current values are substituted from the other equations above. The purpose of this is to calculate the maximum output current of the IC and after comparison, determine if the selected IC is suitable for the converter circuit. The maximum switch current can only be calculated if the maximum current output of the IC is above the value of maximum current output of the application. The maximum switch current is as shown below:

$$I_{SW(max)} = \frac{I_{OUT(max)}}{1 - D} + \frac{\Delta I_L}{2} \quad (6)$$

From the calculations above, the maximum current value that components such as inductor, switches and diode have to be able to withstand.

The next selection of component is the diode, in which it is the rectifier type. In normal conditions, a Schottky diode should be used as it is known to have minimum losses. The value of forward current threshold needs to be same with the maximum current output of the application. Therefore, the forward current in a rectifying diode. The other calculation based on diode is the power dissipation of the diode .

Usually, the minimum value of input capacitance will be stated in the

datasheet of the IC. This value is

$$\frac{D}{1 - D} = \frac{V_{OUT} + V_{FWD}}{(V_{IN(min)}) + V_{OUT} + V_{FWD}} = \frac{I_{IN}}{I_{OUT}} \quad (2)$$

important to stabilize the input voltage due to peak current requirement of the power supply. The recommended capacitor is that of low equivalent series resistance or better known as ESR .

$$ESR \leq \frac{\Delta V_{RPL}}{\frac{I_{OUT(max)}}{1 - D_{max}} + \frac{\Delta I_L}{2}} \quad (10)$$

The same principle applies for the output capacitor. The ESR, in this case is used to limit the ripple of the output voltage. The ESR value can be calculated as follows:

Eq. (10) can be rearranged to:

$$\Delta V_{RPL} = ESR \times \left( \frac{I_{OUT(max)}}{1 - D_{max}} + \frac{\Delta I_L}{2} \right) \quad (11)$$

Where output ripple voltage can be calculated. The current flowing through an ESR in a capacitor is one of the causes of power dissipation of a capacitor which leads to the increase of internal temperature of the capacitor. This results in the shortened life of a capacitor. The RMS value of this current ripple is based on:

Meanwhile, the power dissipation in the inductor is also caused by the current flowing through it. Power dissipation is also one of the causes of internal temperature increase of the inductor. This ultimately results in the degradation in the insulation winding, which increases core losses in the inductor. The power loss in the inductor is given by:



$$P_{Inductor} = \left( \frac{I_{OUT}}{1-D} \right)^2 \times R_{CU} + P_{Core} \quad (13)$$

In this case, the FETs current rating will also determine the boost design converters maximum output current. The usual type of MOSFET used for boost topology converter is n-channel MOSFET. This is due to the fact that the gate drive is simpler compared to that of p-channel.

The power dissipation of the switch is given by:

$$P_{D,Q1} = \left[ \left( \frac{I_{OUT}}{1-D} \right)^2 \times r_{DS(on)} \times D_{(max)} \right] + \left[ \frac{1}{2} \times V_{OUT} \times \left( \frac{I_{OUT}}{1-D} \right)^2 (t_{rise} + t_{fall}) \times f_{sw} \right] + \left[ Q_{GATE} \times V_{GS} \times f_{sw} \right] \quad (14)$$

## ELECTRIC VEHICLES ADOPTION

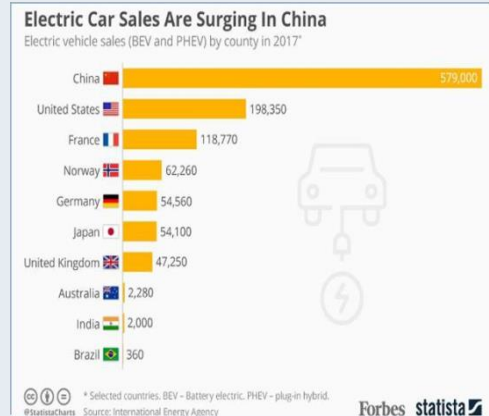

Fig.4 Electric car sales in 2017 in some major countries

## REFERENCES

[1] [www.ergon.com](http://www.ergon.com)

[2] [www.ieeexplore.org](http://www.ieeexplore.org)

# MAGNETIC LEVITATION TRAIN

**Y. Kala Bharati, P. Indumathi,**

**2\4 B Tech.**

## I. INTRODUCTION

Maglev (derived from magnetic levitation) is a system of train transportation that uses two sets of magnets, one set to repel and push the train up off the track, then another set to move the 'floating train' ahead at great speed taking advantage of the lack of friction. Along certain "medium range" routes (usually 200 to 400 miles (320 to 640 km)) Maglev can compete favourably with high-speed rail and airplanes. With Maglev technology, there are no moving parts. The train travels along a guide way of magnets which control the train's stability and speed. Maglev trains are therefore quieter and smoother than conventional trains, and have the potential for much higher speeds. Maglev vehicles have set several speed records and Maglev trains can accelerate and decelerate much faster than conventional trains; the only practical limitation is the safety and comfort of the passengers. The power needed for levitation is typically not a large percentage of the overall energy consumption of a high speed maglev system. Overcoming drag, which makes all land transport more energy intensive at higher speeds, takes the most energy. Vac train technology has been proposed as a means to overcome this limitation. Maglev systems have been much more expensive to construct than conventional train systems.

## II. TECHNOLOGY

In the public imagination, "maglev" often evokes the concept of an elevated monorail track with a linear motor. Maglev systems may be monorail or dual rail and not all monorail trains are maglevs. Some railway

transport systems incorporate linear motors but use electromagnetism only for propulsion, without levitating the vehicle. Such trains have wheels and are not maglevs. Maglev tracks, monorail or not, can also be constructed at grade or underground in tunnels (i.e. not elevated). Conversely, non-maglev tracks, monorail or not, can be elevated or underground too. Some maglev trains do incorporate wheels and function like linear motor-propelled wheeled vehicles at slower speeds but "take off" and levitate at higher speeds.

The two notable types of maglev technology are:

1. Electromagnetic suspensions (EMS), electronically controlled electromagnets in the train attract it to a magnetically conductive (usually steel) track.
2. Electrodynamic suspension (EDS) uses superconducting electromagnets or strong permanent magnets that create a magnetic field, which induces currents in nearby metallic conductors when there is relative movement, which pushes and pulls the train towards the designed levitation position on the guide way. Another technology, which was designed, proven mathematically, peer-reviewed, and patented, but is, as of May 2015, inbuilt, is magneto dynamic suspension (MDS). It uses the attractive magnetic force of a permanent magnet array near a steel track to lift the train and hold it in place. Other technologies such as repulsive permanent magnets and superconducting magnets have seen some research.

## III. SHANGHAI MAGLEV TRAIN

The Shanghai Maglev Train, also known as the Trans rapid, has a top speed of 430 km/h (270 mph). The line is the fastest and currently the first and only, commercially successful, operational high-speed Maglev train, designed to connect Shanghai Pudding International Airport and the outskirts of central Pudding, Shanghai. It covers a distance of 30.5 km (19.0 mi) in 7 or 8 minutes. For the first time, the launch generated wide public interest & media attention, propelling the popularity of the mode of transportation., Currently, high-speed Maglev is only available in China and this transport systems are now operational in just three countries (Japan, South Korea and China). The incremental benefits of maglev technology have often been hard to justify against cost and risk, especially where there is an existing or proposed conventional high speed train line with spare passenger carrying capacity, as in high-speed rail in Europe, the High Speed 2 in the UK and Shinkansen in Japan.

#### **IV.MAGLEV TRAIN IN INDIA**

Moving ahead with the introduction of the high-speed Maglev (magnetic levitation) trains in the country, the Indian Railways has asked Rail India Technical and Economic Service (RITES) to prepare a detailed project report within the next six months. The railways aims to implement the first stretch of the project in less than three years' time After Japan and China, the model of Maglev Train, which is now 600 kilometres per hour, has been developed in India. In fact, the scientists of Raja Ramona Centre for Advanced Technology (RRCAT) of Indore in Madhya Pradesh have succeeded in developing the prototype model of 'maglev' train. The special thing about this train is that it runs floating in the air, not with wheels, and it is called a magnetic system..

#### **V. ADVANTAGES**

- a. They are less expensive to operate and maintain, because the absence of rolling friction means that parts do not wear out quickly . Maglev trains produce little to no air pollution during operation, because no fuel is being burned, and the absence of friction makes the trains very quiet and provides a very smooth ride for passengers.
- b. Due to the lack of physical contact between the track and the vehicle, maglev trains experience no rolling resistance, leaving only air resistance and electromagnetic drag, potentially improving power efficiency.

#### **VI. DISADVANTAGES**

- a. Maglev systems have been much more expensive to construct than conventional train systems, although the simpler construction of maglev vehicles makes them cheaper to manufacture and maintain. Larger train cars are tougher to levitate and require quite a bit more energy, making them less efficient.
- b. While the Maglev can be safer overall, any infrequent accidents that do occur are likely to be more catastrophic due to the elevated guide ways and incredible speeds.

#### **CONCLUSION**

**MAGLEV** train is great transportation method. This will run year round and will be great for the economy and will get you where you need to go even faster than ever. It takes less effort and does not produce CO2. Experts are of the opinion that these trains are a lot safe than their conventional counterparts as they are equipped with state-of-the-art safety systems, which can keep things in control even when the train is cruising at a high speed .

#### **REFERENCES**

- [1].  
[https://en.wikipedia.org/wiki/IEEE\\_Xplore](https://en.wikipedia.org/wiki/IEEE_Xplore)

## DC MICRO GRID SYSTEM

### INTRODUCTION

A DC micro grid maintains a DC bus, which feeds DC loads connected to it. Normally, DC loads are low power rating electronic devices such as laptops, cell phones, wireless phones, DVD players, vacuum cleaners etc. In DC micro grid structure, sources with DC output are connected to DC bus directly, whereas sources with AC output are interfaced to DC bus through AC/DC converter. In Addition to the problem of harmonics due to power electronic converter is not present due to DC nature of output power.

A micro grid is a localized group of electricity sources and loads that normally operates connected to and synchronous with the traditional wide area synchronous grid (macro grid) but can also disconnect to "island mode"- which functions autonomously as physical or economical conditions dictate . In this way, a micro grid can effectively integrate various sources of distributed generation (DG), Especially renewable energy sources (RES). As the number of DC generating renewable energy sources is higher as compared to AC generating sources lesser converter units are required. This increases the overall efficiency of DC micro grid.

### PURPOSE AND ARCHITECTURE OF THE DC MICRO GRID SYSTEM

Following three terms are briefly summarized purposes of DC micro grid system

1) Increase the introduction of distributed PV

units.

2) Reduce energy dissipation and facility costs resulting from AC/DC conversion by integrating the junction between a commercial grid and DC bus which connects PV units and accumulators.

3) Supply power to loads via regular distribution lines (not exclusive lines for emergency) even during the blackout of commercial grids.

The DC micro grid utilizes a DC bus as its backbone and distributes power to a community that consists of several dozens or a hundred of households in a residential area. All the PV units in the community are linked with the DC bus through DC/DC converters. These converters always track the maximum power point of the DC power sources which fluctuates depending on the intensity of solar radiation.

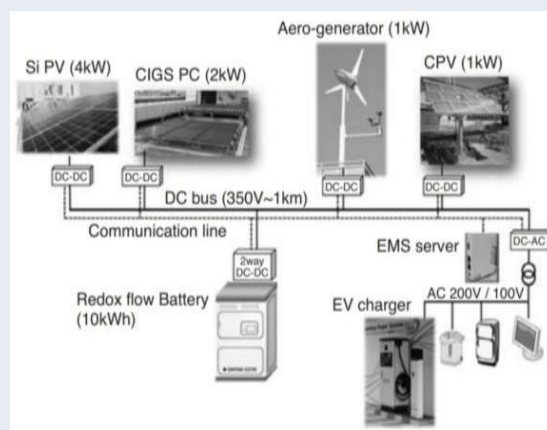

DC micro grid modeling consists of diesel generator, DC load, photovoltaic (PV) generation system, and MAIN/SUB ESS.

**DIESEL GENERATOR:**

The diesel generator is composed of a synchronizer. The controller consists of an exciter for adjusting the output voltage and a governor for adjusting the active power output.

**AC/DC CONVERTERS:**

AC/DC converters that convert the AC voltage supplied from the diesel generator to a DC voltage. The two level pulse width modulation AC/DC converters are modeled as a power conversion device. We control the rated output to maximize the efficiency of the diesel generator.

**ESS:**

ESS modeling is composed of a capacitor, voltage source, and insulated gate bipolar transistor (IGBT). The ESS has a structure of interleaved DC-DC buck boost converter, which operates in charge and discharge modes by switching six IGBT devices. The ESS control method uses voltage and output control methods. In case of MAIN ESS, voltage control is performed to maintain a constant voltage of the DC micro grid.

**OPERATION OF DC MICRO GRID:**

DC micro grid can be divided into 12 modes. In the operation of DC micro grid, we establish an algorithm based on the connection of MAIN ESS, power consumption of load, amount of power generation of distributed generator, and SOC of MAIN/SUB ESS.

The algorithm determines the amount of charge/discharge of each component, control method, and output reference of the diesel generator according to the determined result.

The operation mode in the modeled DC micro grid is largely divided into voltages and output control of ESS for DC bus voltage maintenance

and power supply. The DC based distribution systems reduces facility costs. The power sources and loads are closely located to each other in a community. The excess and deficiency of power are variable factors which should be compensated for a good balance between supply and demand. The compensated system, which consists of storage battery and a bidirectional power converter. Long term fluctuations are smoothed by the battery system.

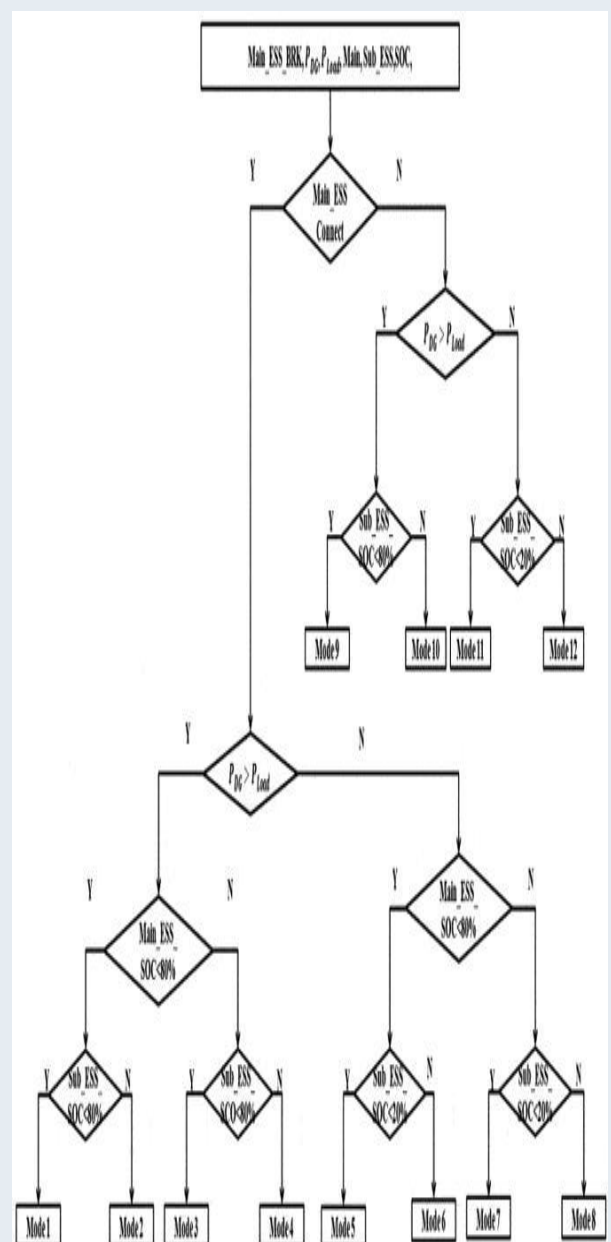

FIG: proposed operation algorithm of DC micro grid

## APPLICATIONS

- 1) High efficiency household
- 2) Renewable energy parks
- 3) Hybrid energy system
- 4) Electric vehicle fast charging station.

## ADVANTAGES:

DC micro grids have major advantages over AC micro grid.

- 1) Higher efficiency
- 2) High reliability
- 3) Higher stability
- 4) Reduced size, weight

## DISADVANTAGES:

Higher initial cost due, in part, to unfamiliarity of the system as well as a general lack of code recognition and efficiency metric recognition leading to the difficult certification and code compliance.

## CONCLUSION:

The hierarchical control of the DC micro grid aims at managing the balance of the instantaneous power in the micro grid on the basis of energy cost optimization with constraints such as storage limits, public grid power limitations, and energy tariffs, which are variable in time. To summarize, the feasibility of the proposed DC micro grid supervisory control structure, which combines grid interaction and energy management with power balancing, is proved by simulation results. Although micro grid refers only to the building scale and involves only a few sources, the idea of parameterized power balancing and interfacing with optimization, as well as smart grid interaction; thus it can be used as a solution for advanced energy management for other micro grids to

optimize local power flow and improve future PV generation.

## REFERENCES:

- [1] Microgrid architecture, control, and operation M. Saad Bin Arif, M. Asif Hasan, in Hybrid-Renewable Energy Systems in Microgrids, 2018.
- [2] Hierarchical Power Sharing Control in DC Microgrids S. Peyghami, F. Blaabjerg, in Microgrid, 2017.

## DEPARTMENT ACTIVITIES

S. No.	Activity type	Name of the Topic/subject	Date	Resource Person/ Judge	Student Participation
1	Guest Lecture	Electrical Engineering Career path in Design, Construction & Commissioning Fields	12/2/18	Mr Suresh Kumar Vengalli, M.Tech, MIET,P.Eng	II, III& IV EEE
2	TESLA Inaugural and Guest Lecture	Power System Scenario-Renewable Energy Sources	28/7/18	Mrs. D.Suman Kalyani, GM Solar Power,APEPDCL Visakhapatnam	II, III& IV EEE
3	Expert Talk	Introduction to MATLAB-SIMULINK	28/07/18	Dr. Devendra	II, III EEE
4	Engineer's Day	Paper Presentations by Students	15/09//18	Dr. Devendra	II, III EEE
5	Industrial visit	Visit of 400/220KV Kalpaka Substation	22/12/18	—	III-EEE
6	Guest Lecture	Energy Audit Conservation and Management	20/12/18	Dr C.V.K. Bhanu	II, III& IV EEE
7	Energy Conservation Day	Energy Conservation and Management (Poster Presentation)	20/12/18	Dr C.V.K. Bhanu (Chief Guest)	II, III& IV EEE



**Guest Lecture on Electrical Engineering Career path in Design, Construction and Commissioning Fields by Mr Suresh Kumar Vengalli, M.Tech, MIET,P.Eng**



**TESLA INAUGURAL by Mrs.D.Suman Kalyani, GM Solar Power,APEPDCL Visakhapatnam**



**Guest Lecture On Power System Scenario-Renewable Energy Sources by Mrs.D.Suman Kalyani**





**Book Opening Ceremony by our Chief Guest: Dr.J.V.Somayajulu, Professor, NIT Warangal**



**Poster Presentation on Energy Conservation Day by Second ,Third ,Fourth Year Students.**

## STUDENT ACTIVITIES

### INDUSTRIAL VISIT:



### INTERNSHIPS:

Sl.No	Name of Student	Event	Year	Title /Organization	Participati on Type
1.	S.Bhargavi (16JG1A0227)	Internship	11-05-2018 To 25-05-2018	"Study of 220KV /132V/33KV Substation" at APTRANSCO	MINI Project
2.	K.Sri Varshini (16JG1A0229)	Internship	11-05-2018 To 25-05-2018	"Study of 220KV /132V/33KV Substation" at APTRANSCO	MINI Project
3.	I.Kavya Sri (16JG1A0211)	Vocational Training	31-05-2018 to 16-06-2018	NMTC Ltd., Chattisgrah	Vocational Trainee

**PAPER PRESENTATION:**

Sl.No	Name of Student	Event	Year	Title /Organization	Participation Type
1.	S.Bhargavi (16JG1A0227)	Paper Presentation	2018	" A study on AC Drives for Plug-in Electric Vehicles" GVPCEW in the magazine INGENEIUR	Best paper
2.	K.Sai Mani Manjula (16JG1A0213)	Paper Presentation	2018	" A study on AC Drives for Plug-in Electric Vehicles" GVPCEW in the magazine INGENEIUR	Best paper
3.	H.Akhila Sarvani (16JG1A0210)	Paper Presentation	2018	" A study on AC Drives for Plug-in Electric Vehicles" GVPCEW in the magazine INGENEIUR	Best paper
4.	S.Roshini (17JG5A0214)	Paper Presentation	2018	"Fuel Cells - Fuelling the Future", GVPCEW	Participated
5	P.S.Lakshmi Tejaswi (16JG1A0230)	Paper Presentation	2018	"Green Building", GVPCEW	participated
6	Ch.Vatsalya (16JG1A0236)	Paper Presentation	2018	"Green Building", GVPCEW	participated
7	Y.Kala Bharathi (16JG1A0239)	Paper Presentation	2018	"Fundamentals of PMBLDC", GVPCEW	participated
8	T.Mounika (16JG1A0233)	Paper Presentation	2018	" Review of Different DC-Dc Converters used for Renewable Energy Applications", GVPCEW	participated
9	K.Sri Varshini (16JG1A0229)	Paper Presentation	2018	" Review of Different DC-Dc Converters used for Renewable Energy Applications", GVPCEW	participated
10	R.Radhika (16JG1A0226)	Paper Presentation	2018	" Switchgear Protection", GVPCEW	participated

11	I.Kavya Sri (16JG1A0211)	Paper Presentation	2018	"Fundamentals of PMBLDC", GVPCEW	participated
12	L.Yasawini (16JG1A0218)	Paper Presentation	2018	" Artificial Intelligence in Power Systems" , GVPCEW	participated
13	B.Vasanthi (17JG5A0203)	Paper Presentation	2018	"Fuel Cells - Fuelling the Future", GVPCEW	participated
14	M.Niharika (17JG5A0211)	Paper Presentation	2018	"Fuel Cells - Fuelling the Future", GVPCEW	participated

#### WORK SHOPS ATTENDED:

1	K Girija Rani	Basics of Electronics and Robotics - workshop	Saarang 2018	IIT Madras, 10- 14 <sup>Th</sup> jan, 2018	Participation
2	K Sri Varshini	Robotics Workshop	TechnoXian	GMRIT, 2 and 3ed February, 2018	Participation
3	Shabosti Bose	Basics of Electronics and Robotics - workshop	Saarang 2018	IIT Madras, 10- 14 <sup>Th</sup> jan, 2018	Participation
4	Ch hari Priyanka	Basics of Electronics and Robotics - workshop	Saarang 2018	IIT Madras, 10- 14 <sup>Th</sup> jan, 2018	Participation
5	Y Jhansi	Basics of Electronics workshop	MSP 430	IIT Madras, 10- 14 <sup>Th</sup> jan, 2018	Participation
6	V Syamala Amani	Basics of Electronics workshop	MSP 430	IIT Madras, 10- 14 <sup>Th</sup> jan, 2018	Participation
7	Y Kala Bharathi	Basics of Electronics workshop	MSP 430	IIT Madras, 10- 14 <sup>Th</sup> jan, 2018	Participation
8	K Sri Varshini	Basics of Finance workshop	Finance 360	IIT Madras, 10- 14 <sup>Th</sup> jan, 2018	Participation

**CO-CURRICULAR ACTIVITIES:**

1	K.Usha Rani	KHO-KHO	JNTU, Kakinada	Inter University KHO-KHO selections, 22nd Sept,2017	Participation
2	H.Akhila Sarvani	KHo-KHo	JNTU, Kakinada	Inter University KHO-KHO selections,22nd Sept,2017	Participation
3	K.Usha Rani	Volleyball	JNTU, Narsaraopeta	Inter University volley ball, 8th Oct, 2017	Participation
4	G. Kalpana	Chess	Gayatri Vidya Parishad College of Engg. (A)	Inter University Selections, 10th October, 2017	Participation
5	K.Usha Rani	Batminton	Aditya Engineering College, Surampalem	JNTUK-Intercollege Central Zone Sports meet,2nd - 4th March, 2018	Participation
6	K.Usha Rani	Table Tennis	Aditya Engineering College, Surampalem	JNTUK-Intercollege Central Zone Sports meet,2nd - 4th March, 2018	Participation
7	G. Kalpana	Chess	Aditya Engineering College, Surampalem	JNTUK-Intercollege Central Zone Sports meet,2nd - 4th March, 2018	Participation

**STUDENT CORNER**

**SPECIAL TALENTS:**



- Art by  
U.Bhuvaneshwari(16JG1A0234)



-Art by,  
L. Bhavana(18JG1A0216)

## Everyone has a Story

A young man in his twenties was seeing out from the train's window shouted...

"Father, look at the trees! They are going behind!"

The young man's father smiled at the man and a young couple sitting nearby, looked at the young man's childish comment with pity.

Suddenly, the young man exclaimed again.

"Father, look at the clouds! They are all running with us!"

The couple couldn't resist and said to the old man.

"Why don't you take your son to a good doctor?"

The old man smiled and said

"We did and we are just coming from the hospital. My son was blind from birth and he just got his vision today."

DO NOT JUDGE OTHERS BY YOUR OWN STANDARDS. FOR EVERYONE

**Moral:** Every person in the world has a story. Don't judge people before you truly know them. The truth might surprise you.

Puzzles:

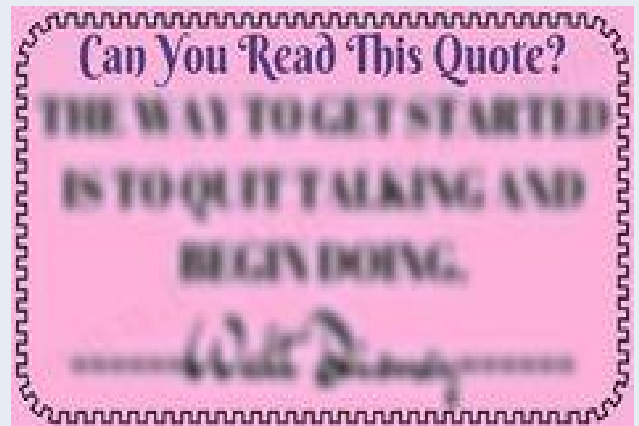
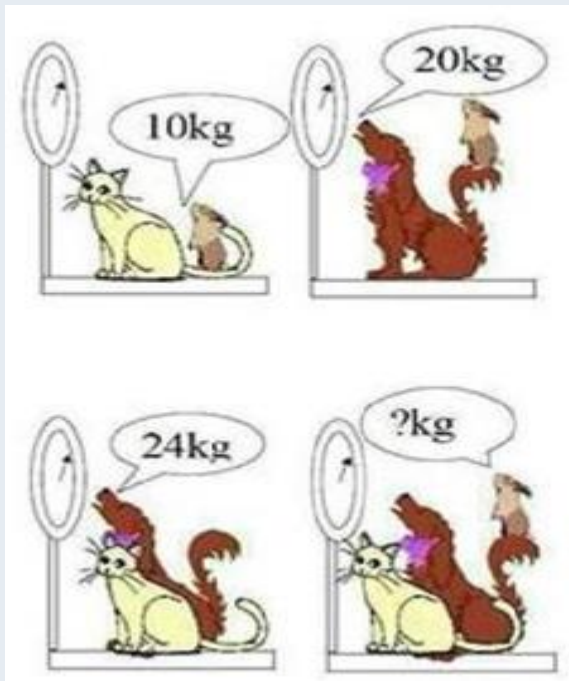

How Many Squares  
Are There?

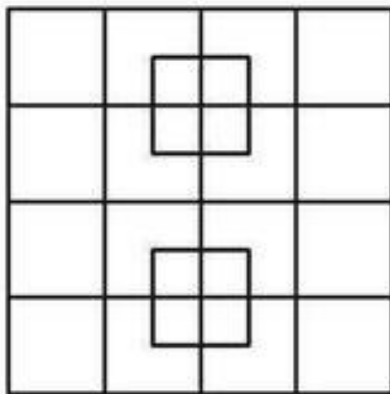

brainiacs.com





**Across**

- 4 A closed circuit in which the current divides into two or more paths before recombining to complete the circuit
- 7 Electric discharge resulting from the accumulation of electric charge on an insulated body.
- 9 An electric circuit connected so that current passes through each circuit element in turn without branching
- 10 A device used to transfer electric energy from one circuit to another, especially a pair of multiply wound, inductively coupled wire coils that effect such a transfer with a change in voltage, current, phase, or other electric characteristics
- 11 An electric current flowing in one direction only.
- 13 A structural or procedural diagram, especially of an electrical or mechanical system
- 14 any phenomenon associated with stationary or moving electrons, ions, or other charged particles
- 15 A force that resists the relative motion or tendency to such motion of two bodies or substances in contact.
- 18 A piece of magnetic material that retains its magnetism after it is removed from a magnetic field
- 19 A magnet consisting essentially of a coil of insulated wire wrapped around a soft iron core that is magnetized only when current flows through the wire.
- 22 the process by which electrical or magnetic properties are transferred, without physical contact, from one circuit or body to another

**Down**

- 1 The opposition of a body or substance to current passing through it, resulting in a change of electrical energy into heat or another form of energy.
- 2 A primary cell having a liquid electrolyte
- 3 a flow of electric charge
- 5 electric current that reverses its direction of flow in a regular pattern
- 6 a cell in which the electrolyte exists in the form of a paste, is absorbed in a porous medium, or is otherwise restrained from flowing.
- 8 one of the basic properties of the elementary particles of matter giving rise to all electric and magnetic forces and interactions.
- 12 The International System unit of electric potential and electromotive force, equal to the difference of electric potential between two points on a conducting wire carrying a constant current of one ampere when the power dissipated between the points is one watt
- 16 the passage of electricity through a conductor
- 17 an electromotive force or potential difference expressed in volts
- 20 Is usually formulated as  $V = IR$ , where  $V$  is the potential difference, or voltage,  $I$  is the current, and  $R$  is the resistance of the conductor.
- 21 base unit for electrical current

## CONTRIBUTIONS & ACHIVEMENTS

Our students have been placed in various companies like INFOSYS, TCS, GGK TECH and few more.



### NPTEL certifications:



## TOPPERS OF THE YEAR

S. No.	Roll No.	Name of the student	Position.
1.	15JG1A0239	Siripuram Yamini	First
2.	16JG1A0239	Yeruva Kala Bharathi	First
3.	17JG5A0231	Udiyana Ramya	First

## CAREER OPPORTUNITIES

### TOP UNIVERSITIES

- Massachusetts Institute of Technology
- Stanford University
- Carnegie Mellon University
- Harvard University
- The University of California, Berkeley (UCB)
- Princeton University

### TOP JOB SEEKERS WEBSITES

- Indeed
- Vacancyopen
- Monster
- Naukri
- TimesJobs
- Fresherworld

### TOP IMPROVEMENT WEBSITES

- Energypedia
- Coursera
- edx
- NPTEL courses

## EDITORIAL TEAM

<b>Prof. Dr. E V Prasad</b>	: Director, GVP College of Engineering for Women
<b>Prof. Dr. K S Rao</b>	: Principal, GVP College of Engineering for Women
<b>Prof. Dr. G Sudheer</b>	: Vice Principal, GVP College of Engineering for Women
<b>Dr. R.V.S.Lakshmi Kumari</b>	: HOD, Department of Electrical & Electronics Engineering
<b>Mrs. V.Sree Vidhya</b>	: Assistant Professor, Department of EEE
<b>H. Akhila Sarvani</b>	: 16JG1A0210
<b>K.Sri Varshini</b>	: 16JG1A0229
<b>Ch.Sruthi Varma</b>	: 16JG1A0204
<b>B.Keerthi</b>	: 17JG1A0208
<b>U.Ramya</b>	: 17JG1A0231
<b>P.Sujitha</b>	: 18JG1A0222

**For Any Suggestions Mail to : [eeemagazine@gvpcew.ac.in](mailto:eeemagazine@gvpcew.ac.in)**